

**PART I**  
**Total Value: 50%**

**Instructions: Shade the letter of the correct answer on the computer scorable answer sheet provided.**

1. What is the direction of acceleration for any projectile?  
 (A) up  
 (B) down  
 (C) left  
 (D) right
  
2. What is the range of a projectile launched horizontally at 15 m/s with a flight time of 4.5 s?  
 (A) 3.3 m  
 (B) 59 m  
 (C) 68 m  
 (D) 99 m
  
3. A rock is launched with a horizontal velocity of 3.0 m/s and a vertical velocity of 4.0 m/s. What is the magnitude of the velocity of the rock at its maximum height?  
 (A) 0 m/s  
 (B) 3.0 m/s  
 (C) 4.0 m/s  
 (D) 5.0 m/s
  
4. A projectile is launched from ground level with an initial velocity of 65 m/s at an angle of  $60.0^\circ$  above the horizontal. How much time does it take to return to ground level?  
 (A) 2.4 s  
 (B) 3.4 s  
 (C) 5.6 s  
 (D) 11 s
  
5. What is the maximum height of a projectile launched at 120 m/s at an angle of  $30.0^\circ$  above the horizontal.  
 (A) 3.1 m  
 (B) 5.3 m  
 (C) 180 m  
 (D) 550 m
  
6. If the 5.0 kg box shown below is at rest on the incline, what is the net force acting on it?

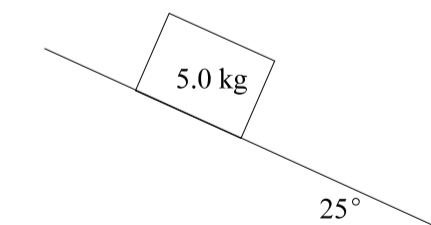

- (A) 0 N  
 (B) 5.0 N  
 (C) 21 N  
 (D) 49 N

7. A box is pushed up a frictionless inclined plane as shown below. Which free body diagram represents this situation?

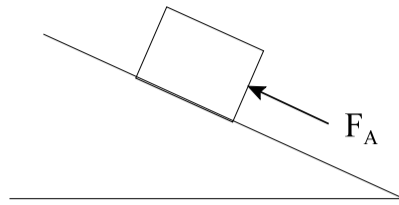

(A)



(B)

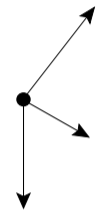

(C)

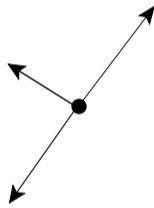

✓

(D)

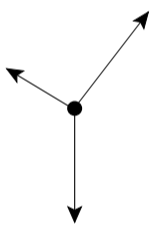

8. What is the magnitude of the acceleration of the object below if the force of friction is 7.0 N?

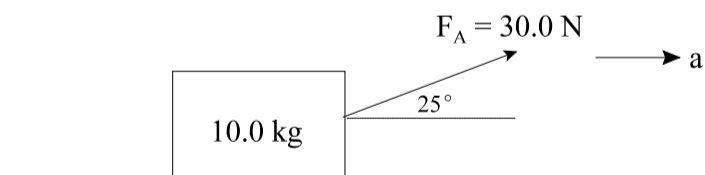

✓

- (A) 0.57 m/s<sup>2</sup>  
 (B) 2.0 m/s<sup>2</sup>  
 (C) 2.3 m/s<sup>2</sup>  
 (D) 2.7 m/s<sup>2</sup>

9. If the coefficient of kinetic friction between the 5.0 kg object and the table is 0.17, what is the magnitude of the acceleration of the system below?

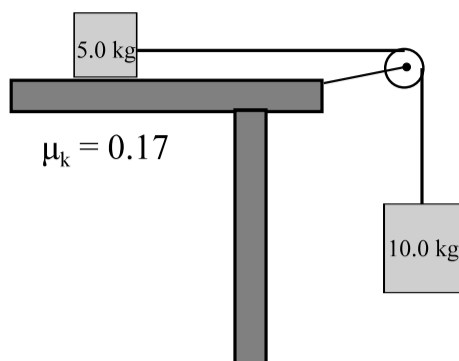

- ✓ (A) 6.0 m/s<sup>2</sup>  
 (B) 6.5 m/s<sup>2</sup>  
 (C) 9.0 m/s<sup>2</sup>  
 (D) 9.8 m/s<sup>2</sup>

10. A block is launched up a frictionless incline with an initial speed of 5.5 m/s as shown. What is the maximum displacement,  $d$ , of the block up the incline?

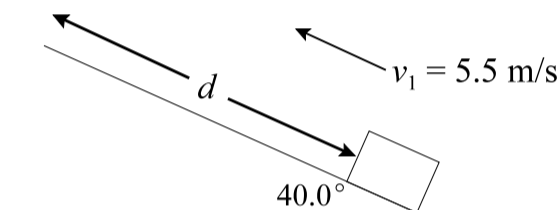

- (A) 0.44 m  
 (B) 1.5 m  
 (C) 2.0 m  
 ✓ (D) 2.4 m

11. What is the direction of the centripetal acceleration for an object moving in a horizontal circle?

- (A) up  
 (B) down  
 (C) away from the center  
 ✓ (D) towards the center

12. A ball attached to a string is swung in a vertical circle. If the string breaks at point X, which path will the ball follow at the instant the string breaks?

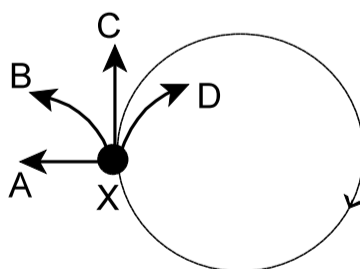

- (A) A  
 (B) B  
 ✓ (C) C  
 (D) D

13. A ball on a string is spun in a horizontal circle. If the speed remains constant and the radius is halved, by what factor will the centripetal acceleration change?

(A)  $\frac{1}{4}$   
(B)  $\frac{1}{2}$   
✓ (C) 2  
(D) 4

14. An object of mass 20.0 kg undergoes 50 rotations in 25 s making a circle of radius 0.95 m. What is the centripetal force experienced by the object?

(A)  $1.9 \times 10^2$  N  
(B)  $2.5 \times 10^2$  N  
✓ (C)  $1.5 \times 10^3$  N  
(D)  $3.0 \times 10^3$  N

15. A 4.0 kg ball on a string is swung in a horizontal circle at a speed of 3.5 m/s. If the tension in the string is 51 N, what is the radius of the circular path traced out by the ball?

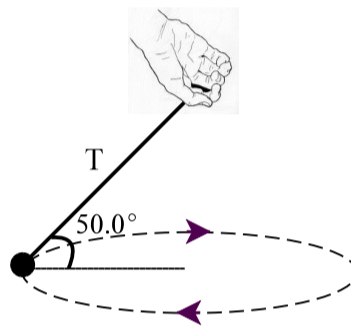

(A) 0.43 m  
(B) 0.67 m  
✓ (C) 1.3 m  
(D) 1.5 m

16. Which is necessary for static equilibrium?

(A)  $\vec{F}_{\text{net}} \neq 0, \vec{\tau}_{\text{net}} \neq 0$   
(B)  $\vec{F}_{\text{net}} \neq 0, \vec{\tau}_{\text{net}} = 0$   
(C)  $\vec{F}_{\text{net}} = 0, \vec{\tau}_{\text{net}} \neq 0$   
✓ (D)  $\vec{F}_{\text{net}} = 0, \vec{\tau}_{\text{net}} = 0$

17. A 45 N force is applied at an angle of  $35^\circ$  to a door at a distance of 0.75 m from the hinge. What is the magnitude of the torque produced by this force?

✓ (A) 19 N·m  
(B) 28 N·m  
(C) 34 N·m  
(D) 45 N·m

18. For the suspended mass shown below, what is the magnitude of the tension,  $T$ , in each cable?

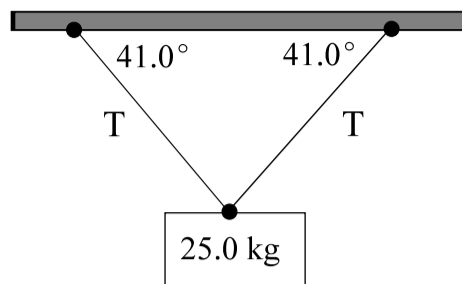

- (A) 123 N  
(B) 162 N  
✓ (C) 187 N  
(D) 373 N
19. Two students are balanced on a uniform seesaw that is supported at the center. If student X with mass 65 kg is 1.2 m from the pivot point on one side of the seesaw, how far from the pivot point is student Y with mass 55 kg?
- (A) 0.71 m  
(B) 1.0 m  
✓ (C) 1.2 m  
(D) 1.4 m
20. If the 3.20 kg uniform beam shown is in static equilibrium, what is the magnitude of  $F_2$ ?

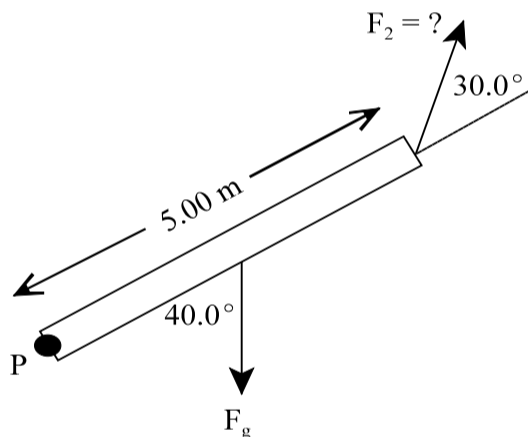

- ✓ (A) 13.9 N  
(B) 20.2 N  
(C) 40.3 N  
(D) 80.6 N
21. Which describes why a plastic comb that has been pulled through hair becomes negatively charged?
- ✓ (A) gains electrons from the hair  
(B) gains protons from the hair  
(C) loses electrons to the hair  
(D) loses protons to the hair

22. Spheres X and Y are on insulated stands as shown below. Sphere X, which is positively charged, comes into brief contact with sphere Y, which is neutral. When X and Y are separated what will be the charge on each sphere?

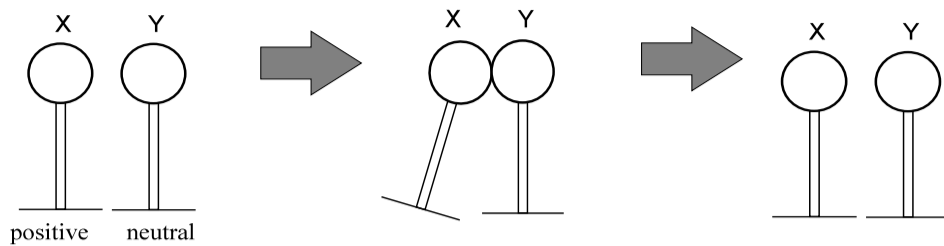

- |       | X        | Y        |
|-------|----------|----------|
| ✓ (A) | positive | positive |
| (B)   | positive | negative |
| (C)   | negative | positive |
| (D)   | neutral  | neutral  |
23. The electrostatic force between two charged spheres, X and Y, doubles. What could explain this situation?
- ✓ (A) The charge on only sphere Y has doubled.  
 (B) The charge on only sphere Y has halved.  
 (C) The distance between spheres X and Y has doubled.  
 (D) The distance between spheres X and Y has halved.
24. What are the charges on spheres X and Y below?

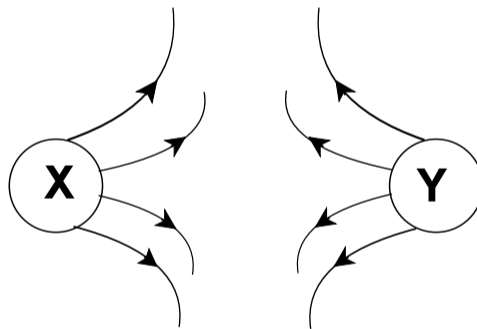

- |       | X        | Y        |
|-------|----------|----------|
| (A)   | negative | negative |
| (B)   | negative | positive |
| (C)   | positive | negative |
| ✓ (D) | positive | positive |
25. What is the magnitude of the electric field at a point 0.012 m from a charge of 0.28 C?
- (A)  $1.9 \times 10^3$  N/C  
 (B)  $2.1 \times 10^{11}$  N/C  
 (C)  $4.9 \times 10^{12}$  N/C  
 ✓ (D)  $1.8 \times 10^{13}$  N/C

26. If two positive point charges are placed 3.0 m apart as shown below, what is the magnitude of the electric field at point P midway between the two charges?

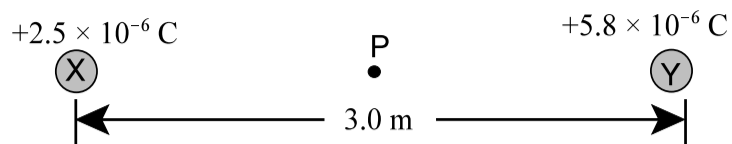

- (A) 0 N/C  
 (B) 8 300 N/C  
 ✓ (C) 13 000 N/C  
 (D) 33 000 N/C
27. The work required to move an electric charge between two points in an electric field is 0.0045 J. If the potential difference between these points is 12 V, what amount of charge is moved?
- ✓ (A)  $3.8 \times 10^{-4} \text{ C}$   
 (B)  $5.4 \times 10^{-2} \text{ C}$   
 (C)  $1.2 \times 10^2 \text{ C}$   
 (D)  $2.7 \times 10^3 \text{ C}$
28. Which circuit is correctly wired to measure both the current and the voltage for the 3 Ω resistor?

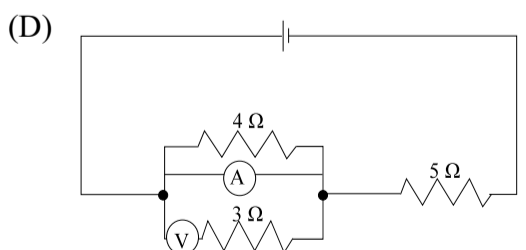
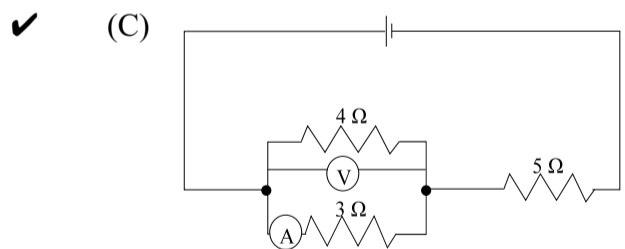
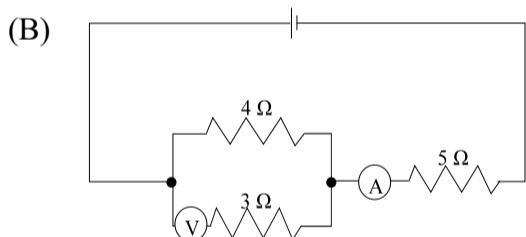
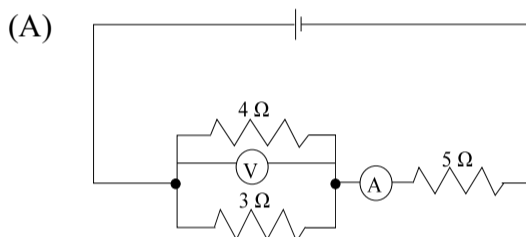

29. Which is always true for resistors in parallel and resistors in series?

	Resistors in Parallel	Resistors in Series
(A)	equal currents	equal currents
(B)	equal currents	equal voltage drops
✓ (C)	equal voltage drops	equal currents
(D)	equal voltage drops	equal voltage drops

30. If two  $75\ \Omega$  resistors are connected in parallel with an 18 V battery, how much current passes through one of the resistors?

- (A) 0.12 A
- ✓ (B) 0.24 A
- (C) 0.48 A
- (D) 4.2 A

31. The diagram below shows part of an electric circuit. What is the current through resistor  $R_1$ ?

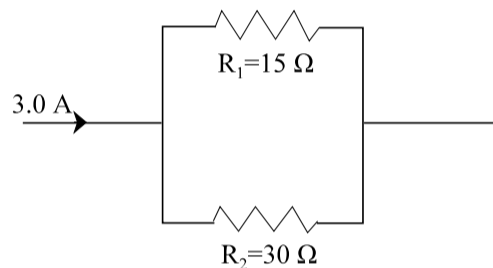

- (A) 1.0 A
- (B) 1.4 A
- ✓ (C) 2.0 A
- (D) 3.0 A

32. A potential difference of 12 V causes 0.35 C of electric charge to pass through a resistor in 2.6 s. How much power does the resistor dissipate?

- ✓ (A) 1.6 W
- (B) 4.2 W
- (C) 11 W
- (D) 89 W

33. Which is used to determine the direction of magnetic field lines around a bar magnet?

- ✓ (A) north magnetic pole
- (B) south magnetic pole
- (C) positively charged particle
- (D) negatively charged particle

34. What is the direction of the magnetic force on an electron moving near a current-carrying wire as shown?

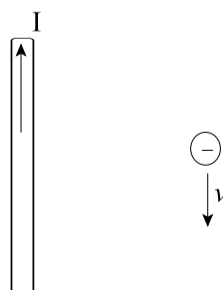

- (A) left
- ✓ (B) right
- (C) into the page
- (D) out of the page

35. A charged particle of  $1.35 \times 10^{-7} \text{ C}$  moves with a speed of  $3.0 \times 10^4 \text{ m/s}$  perpendicular to a uniform magnetic field of  $0.40 \text{ T}$ . What is the magnitude of the magnetic force on the charged particle?

- ✓ (A)  $1.6 \times 10^{-3} \text{ N}$
- (B)  $2.5 \times 10^{-3} \text{ N}$
- (C)  $4.3 \times 10^5 \text{ N}$
- (D)  $5.4 \times 10^5 \text{ N}$

36. A  $1.0 \text{ m}$  wire carrying a current of  $10 \text{ A}$  is oriented parallel to a uniform magnetic field of  $0.40 \text{ T}$ . What is the magnitude of the force that it experiences?

- ✓ (A)  $0 \text{ N}$
- (B)  $2.0 \text{ N}$
- (C)  $4.0 \text{ N}$
- (D)  $8.0 \text{ N}$

37. What is the current in a straight conductor if it produces a magnetic field of  $1.5 \times 10^{-5} \text{ T}$  at  $0.15 \text{ m}$  from the conductor?

- (A)  $0.028 \text{ A}$
- (B)  $0.089 \text{ A}$
- ✓ (C)  $11 \text{ A}$
- (D)  $35 \text{ A}$

38. A  $1.50 \text{ m}$  long conductor, “floating” above a  $5.00 \times 10^{-3} \text{ T}$  magnetic field, is held in static equilibrium by the field. If it is perpendicular to the magnetic field and carries a current of  $25.0 \text{ A}$ , what is the mass of the conductor?

- (A)  $1.28 \times 10^{-2} \text{ kg}$
- ✓ (B)  $1.91 \times 10^{-2} \text{ kg}$
- (C)  $1.88 \times 10^{-1} \text{ kg}$
- (D)  $2.55 \times 10^0 \text{ kg}$

39. The bar magnet below is pulled out of a solenoid as shown. Given the direction of the induced current in the solenoid, what will be the polarity of X and Y?

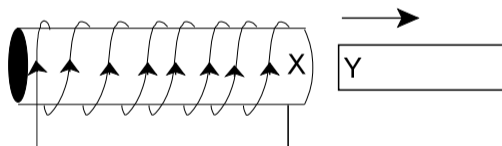

	X	Y
(A)	north	north
✓ (B)	north	south
(C)	south	north
(D)	south	south

40. In a magnetically levitated train, a permanent magnet mounted on the train is repelled by an electromagnet in the rail to keep the train above the rail. If the permanent magnet in each diagram below is identical and the current is the same in each electromagnet, which design will produce the greatest repulsion?

✓

(A)

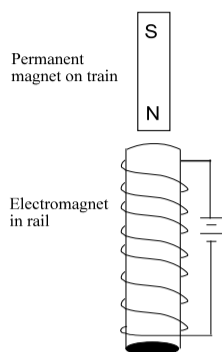

(B)

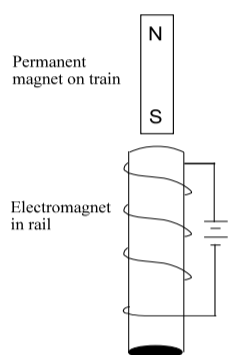

(C)

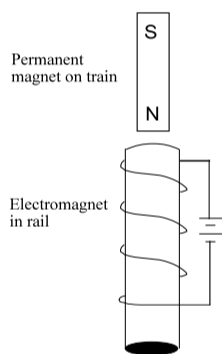

(D)

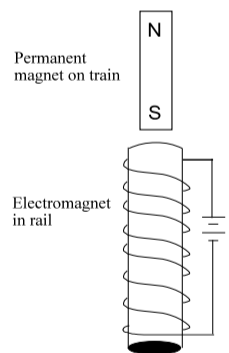

41. What is the energy of one photon of green light with frequency  $6.0 \times 10^{14}$  Hz?

(A)  $3.3 \times 10^{-40}$  J

(B)  $3.3 \times 10^{-38}$  J

✓

(C)  $4.0 \times 10^{-19}$  J

(D)  $4.0 \times 10^{-17}$  J

42. If the smallest orbital radius of an electron in a hydrogen atom is  $r_1$ , what is the radius of the third orbit?

- (A)  $1.7 r_1$
- (B)  $3 r_1$
- (C)  $6 r_1$
- ✓ (D)  $9 r_1$

43. The deBroglie wavelength of a proton is  $5.57 \times 10^{-7}$  m. What is the speed of the proton?

- (A)  $1.19 \times 10^{-27}$  m/s
- (B)  $3.57 \times 10^{-19}$  m/s
- (C)  $1.28 \times 10^{-9}$  m/s
- ✓ (D)  $7.11 \times 10^{-1}$  m/s

44. Which transition of an electron in a hydrogen atom will result in an energy release of 0.306 eV?

- (A)  $n = 3$  to  $n = 4$
- (B)  $n = 4$  to  $n = 3$
- (C)  $n = 4$  to  $n = 5$
- ✓ (D)  $n = 5$  to  $n = 4$

45. What is the number of protons, neutrons and electrons in a  ${}^{93}_{41}\text{Nb}$  atom?

	Protons	Neutrons	Electrons
--	---------	----------	-----------

46. Complete the following nuclear reaction,

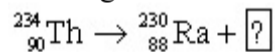

- ✓ (A)  $\alpha$
- (B)  $\beta$
- (C)  $\beta^+$
- (D)  $\gamma$

47. Which is classified as a nuclear fission reaction?

- (A) A heavy nucleus splits into lighter atoms and energy is absorbed.
- ✓ (B) A heavy nucleus splits into lighter atoms and energy is released.
- (C) Smaller nuclei join and energy is absorbed.
- (D) Smaller nuclei join and energy is released.

48. What is the mass difference in a nuclear reaction if the energy released is  $2.98 \times 10^{-11}$  J?

- ✓ (A)  $3.31 \times 10^{-28}$  kg
- (B)  $9.93 \times 10^{-20}$  kg
- (C)  $2.78 \times 10^{-8}$  kg
- (D)  $8.94 \times 10^{-3}$  kg

49. After 15 days, a sample of a radioactive gas decays to 65% of its original mass. What is the half-life of this radioactive gas?

- (A) 7.5 days
- (B) 9.3 days
- (C) 22 days
- ✓ (D) 24 days

50. The diagram below shows the energy levels of a hydrogen atom where the arrows A, B, C, and D indicate transitions of electrons in the atom. Which transition would result from the emission of a photon with the most energy?

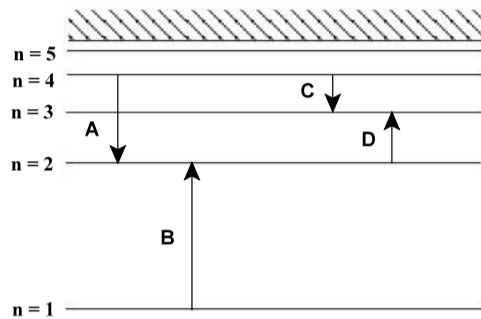

- ✓ (A) A
- (B) B
- (C) C
- (D) D

**PART II**  
**Total Value: 50%**

**Instructions:** Complete all items in this section. Your responses should be clearly presented in a well organized manner with proper use of units, formulae and significant figures where appropriate.

Value

- 3% 51.(a) In a laboratory activity, students launch a toy car horizontally off a table with a speed of 3.6 m/s as shown. If a 0.25 m wide target is placed 1.0 m from the base of the table, determine whether the car will hit the target.

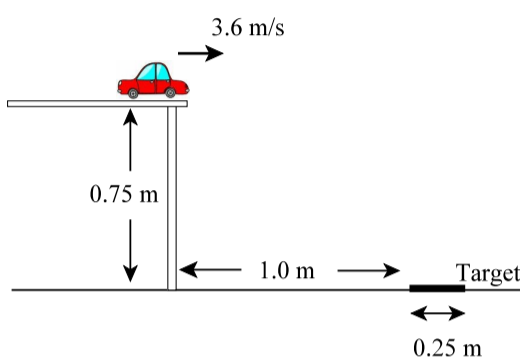

$$d_y = v_{1y}t - \frac{1}{2}a_y t^2$$

$$-0.75\text{m} = 0 - 4.9t^2 \quad (0.5 \text{ marks})$$

$$t = 0.39\text{s} \quad (0.5 \text{ marks})$$

$$d_x = v_x t = (3.6\text{m/s})(0.39\text{s}) \quad (0.5 \text{ marks})$$

$$d_x = 1.4\text{m} \quad (0.5 \text{ marks})$$

The distance from the base of the table to the far end of the target is 1.25 m. (0.5 marks)

Therefore the car will overshoot the target. (0.5 marks)

- 2% (b) Explain why beginning jugglers prefer large dwell ratios, while professional jugglers prefer smaller dwell ratios.

---

With a large dwell ratio, the ball is in the juggler's hands for a longer period of time. This gives the juggler more time to throw accurately which is helpful for a novice juggler. (1 mark)

---



---

With a smaller dwell ratio the juggler has the ball in his/her hands for a shorter period of time. This is good for a professional juggler who is more interested in shifting juggling patterns and hand repositioning. (1 mark)

---

**Value**

- 4% 51.(c) In the diagram shown, the coefficient of friction between the 9.0 kg block and the horizontal surface is 0.15, while the incline is frictionless. Calculate the magnitude of the tension in the rope.

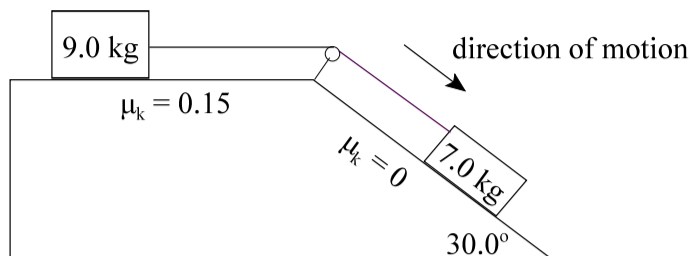

$$a = \frac{F_{net}}{m} = \frac{F_{gx} - F_{fr}}{m_{total}} \quad (0.5 \text{ marks})$$

$$a = \frac{(7.0\text{kg})(9.80\text{m/s}^2)(\sin 30.0^\circ) - (0.15)(9.0\text{kg})(9.80\text{m/s}^2)}{9.0\text{kg} + 7.0\text{kg}} \quad (1.5\text{marks})$$

$$a = \frac{34.3\text{kg} \cdot \text{m/s}^2 - 13.23\text{kg} \cdot \text{m/s}^2}{16.0\text{kg}}$$

$$a = 1.3\text{m/s}^2 \quad (0.5 \text{ marks})$$

To find tension, draw a free body diagram for either block. For the 9.0 kg block:

$$T - F_{fr} = F_{net}$$

$$T = F_{net} + F_{fr} \quad (0.5 \text{ marks})$$

$$T = (9.0\text{kg})(1.3\text{m/s}^2) + 13.23\text{kg} \cdot \text{m/s}^2 \quad (0.5 \text{ marks})$$

$$T = 25\text{N} \quad (0.5 \text{ marks})$$

- 4% (d) A roller coaster cart is at the top of a vertical circular loop and is travelling at 9.30 m/s. The total mass of the cart and passengers is 435 kg.
- (i) If the radius of the loop is 4.50 m, calculate the normal force acting on the cart at the top of the loop.

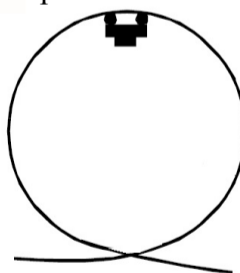

$$F_N = F_C - F_g \quad (0.5 \text{ marks})$$

$$F_N = \frac{mv^2}{r} - mg$$

$$F_N = \frac{(435\text{kg})(9.30\text{m/s})^2}{4.50\text{m}} - (435\text{kg})(9.80\text{m/s}^2) \quad (1 \text{ mark})$$

$$F_N = 8360.7\text{kg} \cdot \text{m/s}^2 - 4263\text{kg} \cdot \text{m/s}^2$$

$$F_N = 4.10 \times 10^3 \text{N} \quad (0.5 \text{ marks})$$

Value

- ii) Calculate the minimum speed required at the top of the loop to keep the cart on the track.

$$F_N = 0 \text{ at minimum speed (0.5 marks)}$$

$$\text{Therefore, } F_C = F_g \text{ (0.5 marks)}$$

$$\frac{mv^2}{r} = mg$$

$$v = \sqrt{rg} \text{ (0.5 marks)}$$

$$v = \sqrt{(4.50\text{m})(9.80\text{m/s}^2)}$$

$$v = 6.6\text{m/s} \text{ (0.5 marks)}$$

- 4% 51.(e) A car is rounding a flat, horizontal turn with radius 51 m. The coefficient of friction between the tires and the road is 0.30.

- i) Calculate the maximum speed at which the car can safely round the turn without skidding.

$$F_C = F_f \text{ (0.5 marks)}$$

$$\frac{mv^2}{r} = \mu_s mg \text{ (0.5 marks)}$$

$$v = \sqrt{\mu_s rg} \text{ (0.5 marks)}$$

$$v = \sqrt{(0.30)(51\text{m})(9.80\text{m/s}^2)}$$

$$v = 12\text{m/s} \text{ (0.5 marks)}$$

Science Communication Skills (1 mark)

- ii) Calculate the angle at which the road must be banked so that the car can safely round the turn when there is no friction between the tires and the road.

$$\tan \theta = \frac{v^2}{rg} \text{ (0.5 marks)}$$

$$\tan \theta = \frac{(12\text{m/s})^2}{(51\text{m})(9.80\text{m/s}^2)}$$

$$\theta = 16^\circ \text{ (0.5 marks)}$$

**Value**

- 3% (f) The wind exerts a force of 13 N on the top of the tree shown below. Calculate the forces,  $F_1$  and  $F_2$ , required for the tree to remain in static equilibrium.

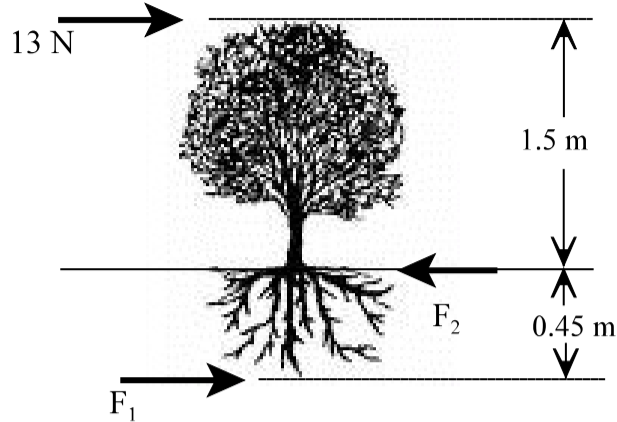

Using  $F_1$  as the pivot point,

$$\tau_{wind} = \tau_{F_2}$$

$$13\text{N}(1.5\text{m} + 0.45\text{m}) = F_2(0.45\text{m}) \quad (1.5 \text{ marks})$$

$$F_2 = 56\text{N} \quad (0.5 \text{ marks})$$

Therefore:

$$F_1 + 13\text{N} = F_2 \quad (0.5 \text{ marks})$$

$$F_1 = 56\text{N} - 13\text{N}$$

$$F_1 = 43\text{N} \quad (0.5 \text{ marks})$$

- 2% 52.(a) Using diagrams and brief explanations, describe how a negative charge on a metal leaf electroscope can be produced by induction.

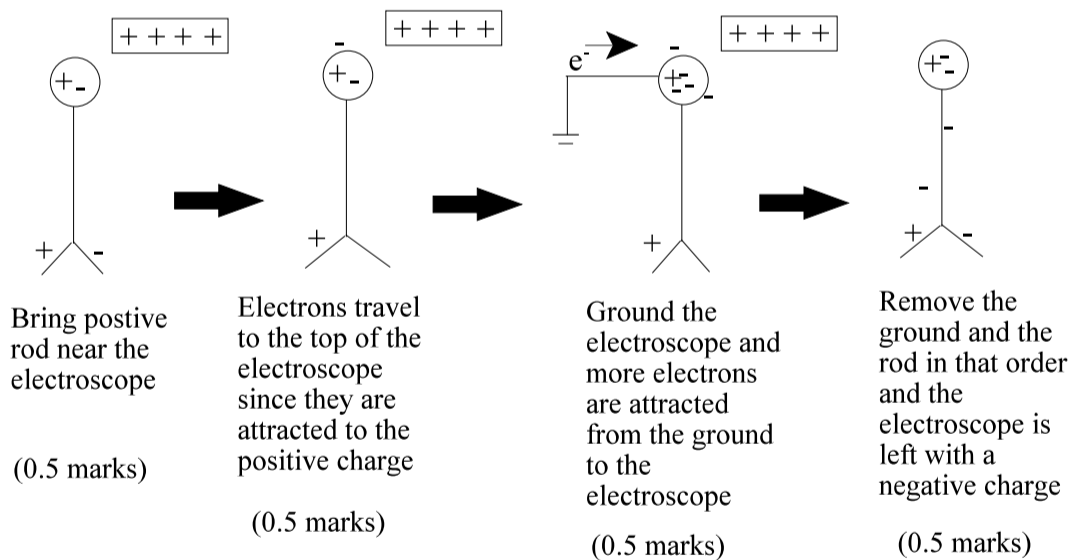

Value

4%

- (b) Three charged objects are arranged as shown. Calculate the net force on Y due to the presence of X and Z.

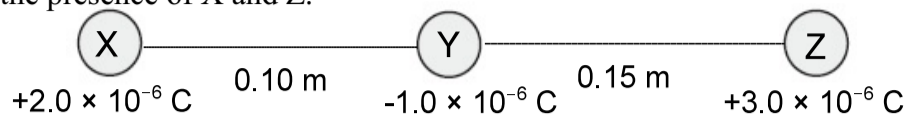

$$F_{x \text{ on } y} = \frac{kQ_x Q_y}{r_{xy}^2} = \frac{(9.0 \times 10^9 \text{ N} \cdot \frac{\text{m}^2}{\text{C}^2})(2.0 \times 10^{-6} \text{ C})(-1.0 \times 10^{-6} \text{ C})}{(0.10 \text{ m})^2}$$

$$F_{x \text{ on } y} = -1.8 \text{ N} \quad (1 \text{ mark})$$

$$F_{z \text{ on } y} = \frac{kQ_z Q_y}{r_{zy}^2} = \frac{(9.0 \times 10^9 \text{ N} \cdot \frac{\text{m}^2}{\text{C}^2})(3.0 \times 10^{-6} \text{ C})(-1.0 \times 10^{-6} \text{ C})}{(0.15 \text{ m})^2}$$

$$F_{z \text{ on } y} = -1.2 \text{ N} \quad (1 \text{ mark})$$

$$F_{\text{net}} = 1.2 \text{ N} - 1.8 \text{ N} = -0.6 \text{ N}$$

$$F_{\text{net}} = 0.6 \text{ N to the left} \quad (1 \text{ mark})$$

Science communication skills                      (1 mark)

3%

- 52.(c) A  $2.5 \times 10^{-5} \text{ kg}$  particle with a charge of  $-1.5 \times 10^{-6} \text{ C}$  is placed in an electric field of strength  $2.2 \times 10^3 \text{ N/C}$  [right] as shown. Determine the magnitude and direction of the acceleration of the particle.

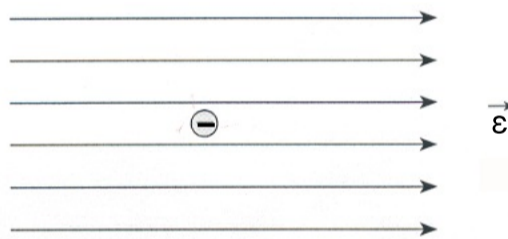

$$\varepsilon = \frac{F}{q}$$

$$\therefore \varepsilon q = F \quad (0.5 \text{ marks})$$

$$\varepsilon q = ma \quad (0.5 \text{ marks})$$

$$a = \frac{\varepsilon q}{m} \quad (0.5 \text{ marks})$$

$$a = \frac{(2.2 \times 10^3 \text{ N/C})(-1.5 \times 10^{-6} \text{ C})}{2.5 \times 10^{-5} \text{ kg}} \quad (0.5 \text{ marks})$$

$$a = -132 \text{ m/s}^2$$

$$a = 132 \text{ m/s}^2 \text{ (left)} \quad (1 \text{ mark})$$

**Value**

- 3% (d) A high voltage power line has a resistivity of  $1.7 \times 10^{-8} \Omega \cdot \text{m}$ , a diameter of 2.2 cm and carries a current of 50.0 A. If a bird lands on the power line, calculate the distance between its feet if the potential difference across its body is  $9.0 \times 10^{-5} \text{ V}$ .

$$R = \frac{\rho L}{A} \text{ where } R = \frac{V}{I}$$

$$\frac{V}{I} = \frac{\rho L}{A} \quad (1 \text{ mark})$$

$$\rho L I = VA \text{ where } A = \pi r^2$$

$$L = \frac{V \pi r^2}{\rho I} \quad (0.5 \text{ marks})$$

$$L = \frac{(9.0 \times 10^{-5} \text{ V})(\pi)(0.011 \text{ m})^2}{(1.7 \times 10^{-8} \Omega \cdot \text{m})(50.0 \text{ A})} \quad (1 \text{ mark})$$

$$L = 0.040 \text{ m} = 4.0 \text{ cm} \quad (0.5 \text{ marks})$$

- 5% 52.(e) Given the circuit in the diagram below, calculate:

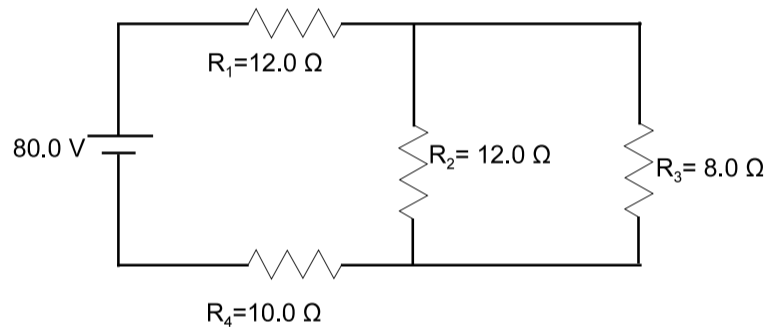

- (i) the voltage drop across  $R_1$ .

$$\frac{1}{R_p} = \frac{1}{12.0 \Omega} + \frac{1}{8.0 \Omega}$$

$$R_p = 4.8 \Omega \quad (0.5 \text{ marks})$$

$$R_T = 12.0 \Omega + 10.0 \Omega + 4.8 \Omega$$

$$R_T = 26.8 \Omega \quad (0.5 \text{ marks})$$

$$I_T = \frac{V_T}{R_T} = \frac{80.0 \text{ V}}{26.8 \Omega} = 2.99 \text{ A} \quad (1 \text{ mark})$$

$$V_1 = I_1 R_1 = (2.99 \text{ A})(12.0 \Omega) = 35.9 \text{ V} \quad (1 \text{ mark})$$

Value

- (ii) the current through  $R_2$ .

$$V_p = I_p R_p = (2.99\text{A})(4.8\Omega) = 14\text{V} \quad (1 \text{ mark})$$

$$I_2 = \frac{V_2}{R_2} = \frac{14\text{V}}{12.0\Omega} = 1.2\text{A} \quad (1 \text{ mark})$$

- 3% (f) An electron is shot perpendicularly into a  $3.25 \times 10^{-4}$  T magnetic field. If the electron moves in a circular path of radius 12.0 cm, calculate the speed of the electron.

$$F_{\text{magnetic}} = F_{\text{centripetal}} \quad (1 \text{ mark})$$

$$qvB \sin \theta = \frac{mv^2}{r}$$

$$qvB = \frac{mv^2}{r} \quad (0.5 \text{ marks})$$

$$qBr = mv$$

$$\therefore v = \frac{qBr}{m} \quad (0.5 \text{ marks})$$

$$v = \frac{(1.6 \times 10^{-19} \text{C})(3.25 \times 10^{-4} \text{T})(0.120 \text{m})}{9.11 \times 10^{-31} \text{kg}} \quad (0.5 \text{ marks})$$

$$v = 6.85 \times 10^6 \text{ m/s} \quad (0.5 \text{ marks})$$

- 3% 53.(a) Light is incident on a metal that has a work function of 2.28 eV. If the maximum kinetic energy of the emitted electrons is  $2.34 \times 10^{-20}$  J, calculate the wavelength of the incident light.

$$W_o = 2.28 \text{ eV} = 3.64(8) \times 10^{-19} \text{ J} \quad (0.5 \text{ marks})$$

$$E_{k\text{max}} = \frac{hc}{\lambda} - W_o$$

$$\frac{hc}{\lambda} = E_{k\text{max}} + W_o$$

$$\frac{hc}{\lambda} = 2.34 \times 10^{-20} \text{ J} + 3.64(8) \times 10^{-19} \text{ J} = 3.88(2) \times 10^{-19} \text{ J} \quad (0.5 \text{ marks})$$

$$\lambda = \frac{hc}{3.88(2) \times 10^{-19} \text{ J}} \quad (0.5 \text{ marks})$$

$$\lambda = 5.12 \times 10^{-7} \text{ m} = 512 \text{ nm} \quad (0.5 \text{ marks})$$

Science communication skills (1 mark)

**Value**

- 2% (b) There are some characteristics of light and subatomic particles that cannot be explained by the wave theory of light. Identify one of these characteristics and describe how quantum theory can explain it.

Various - see text page 697

---



---



---



---



---



---



---

1 mark - identification of the characteristic

---

1 mark - how quantum theory explains it

---



---



---



---

- 2% (c) Radium-226 undergoes the following radioactive decay. Calculate the energy released in the reaction below.

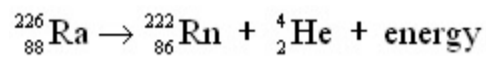

Particle	Mass (kg)
${}_{88}^{226}\text{Ra}$	$3.752 \times 10^{-25} \text{ kg}$
${}_{86}^{222}\text{Rn}$	$3.685 \times 10^{-25} \text{ kg}$
${}_2^4\text{He}$	$6.644 \times 10^{-27} \text{ kg}$

$$\Delta m = 3.752 \times 10^{-25} \text{ kg} - (3.685 \times 10^{-25} \text{ kg} + 6.644 \times 10^{-27} \text{ kg}) \quad (0.5 \text{ marks})$$

$$\Delta m = 5.600 \times 10^{-29} \text{ kg} \quad (0.5 \text{ marks})$$

$$E = mc^2$$

$$E = (5.600 \times 10^{-29} \text{ kg})(3.00 \times 10^8 \text{ m/s})^2 = 5.04 \times 10^{-12} \text{ J} \quad (1 \text{ mark})$$

Value

3% 53. (d) A radioactive sample has a half-life of 2.5 minutes, and the initial activity of the sample is 100 Bq.

- (i) On the grid below, sketch a graph of activity versus time for this sample for the next 7.5 minutes.

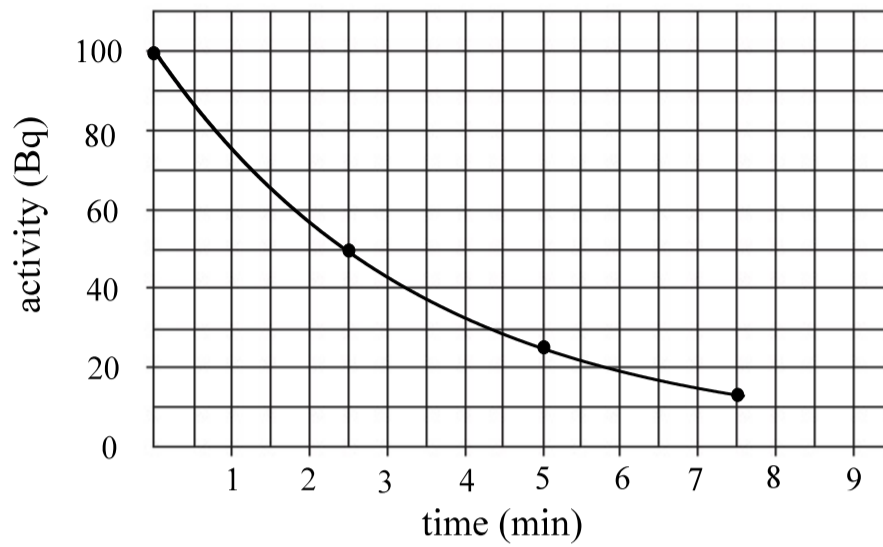

Time (min)	Activity (Bq)
0	100
2.5	50
5.0	25
7.5	12.5

(0.5 marks for each point on curve)

- (ii) Using the graph, determine the activity of this sample at 6.0 minutes.

At 6.0 minutes the activity read from the graph is  $\approx 19$  Bq

(1 mark)