

# **Grading Standards Physics 3204 June 2007**

## **Pre-Marking Appraisal**

The June 2007 physics exam was considered a fair exam, well designed, and of reasonable length and difficulty.

## **Post Marking Report**

### **Marking Standard and Consistency**

Marker reliability was checked by obtaining a random sample of 50 papers that went through the marker panel and marks were assigned to each question on a separate sheet of paper. The 50 exams were put back into the original stack of exams and corrected again when they appeared. The two values were compared and if there were discrepancies, the chief marker would review the scoring with the individual marker.

Throughout the marking process there were statistical analysis ran on item data to enhance reliability and consistency of marking.

Each marker also made on-going notes regarding partial marks and scoring for their particular question. Whenever a non-common error occurred, it was scored by consensus of the board and made note of, for scoring consistency.

### **Summary**

Overall performance in the Physics 3204 examination for June 2007 was similar to that of June 2006. As in past years, however, performance was lower for items that assessed outcomes from core Labs and STSE units. Core Labs and STSE units enrich and enhance material in each unit of the course.

Very often it appeared students did not read questions carefully and critically.

Another concern was mathematical skills. Many students made errors involving orders of operations. As well, many students were able to correctly select formulae and properly place values in the equations, but calculated incorrect answers.

## Commentary on Responses

### Part I – Selected Response - Total Value: 50%

- Item #5: Only 28% of students chose the correct response (a). The majority of students (57%) chose the incorrect response (b). Students may have interpreted the constant speed as a constant acceleration.
- Item #10: Students had difficulty with this item. While the free body diagram should only include all forces acting upon a body (d), students almost equally chose responses that included components of the forces (a) & (b).

**Part II – Constructed Response - Total Value: 50%**

Value  
3%

51.(a) A juggler throws a ball upward at an angle of  $65^\circ$  to the horizontal, with an initial speed of 3.2 m/s. How far apart should the juggler hold her hands in order to catch the ball at the same level from which it was thrown?

**Answer:**

$$v_{1y} = 3.2\sin(65^\circ) = 2.9 \text{ m/s} \quad \mathbf{0.5 \text{ marks}}$$

$$v_{1x} = 3.2\cos(65^\circ) = 1.4 \text{ m/s} \quad \mathbf{0.5 \text{ marks}}$$

First find time to reach max height,  $t_{up} = \frac{v_{2y} - v_{1y}}{a_g} = \frac{0 - 2.9}{-9.80} \quad \mathbf{0.5 \text{ marks}}$

$$t_{up} = 0.30 \text{ s}$$

Total time, is twice time up = 0.60 s  $\mathbf{0.5 \text{ marks}}$

The separation distance,  $d_x$ :  $d_x = v_x t$   
 $d_x = (1.4)(.60) \quad \mathbf{1 \text{ mark}}$   
 $d_x = 0.84 \text{ m}$

**Commentary on Response**

Students did not know how to determine range for a vertical displacement of 0.

**Common Error**

Students calculated the time to reach maximum height, but did not find the total time.

Value

- 3% 51.(b) In the diagram below a dart that is in line with the midpoint of a 0.26 m high target, is thrown toward the target with a speed of 6.0 m/s at a 30.0° angle. Determine whether the dart will hit the target if it is 3.0 m away.

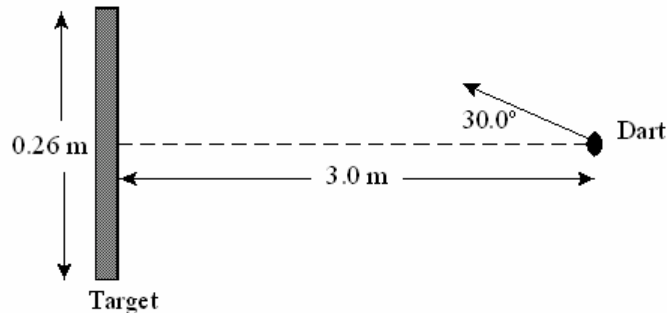

**Answer:**

Find velocity components:

$$v_{1y} = 6.0 \sin(30^\circ) = 3.0 \frac{m}{s} \quad \mathbf{0.5 \text{ marks}}$$

$$v_{1x} = 6.0 \cos(30^\circ) = 5.2 \frac{m}{s} \quad \mathbf{0.5 \text{ marks}}$$

$$t = \frac{d_x}{v_x} = \frac{3.0}{5.2} = 0.58s \quad \mathbf{0.5 \text{ marks}}$$

Then, find the vertical rise on the target in 0.58 s,

$$d_y = v_{1y}t + \frac{1}{2} \cdot a_y t^2$$
$$d_y = (3.0)(0.58) + \frac{1}{2} \cdot (-9.80)(0.58)^2 \quad \mathbf{0.5 \text{ marks}}$$
$$d_y = 0.092m$$

Since half of the target is 0.13 m above the horizontal line of sight, the dart will hit the target at 0.13 m - 0.092 m = 0.04 m from the top edge. **1 mark**

### Commentary on Response

Students misunderstood how projectiles work and failed to realize that there are two possible answers for the time it takes to be at the same vertical displacement (i.e. as the projectile ascends, and as it descends). Depending upon where the target is placed, the projectile may easily overshoot the target. This possibility must be eliminated through proper understanding of vectors.

## Common Errors

Students:

- found the range needed for the dart to return to its original vertical displacement, ignoring the possibility of the dart going over the top of the target
- used the quadratic formula to find the time and made mistakes using the formula
- rearranged the distance formula incorrectly  
(e.g.,  $d = \frac{v}{t}$  instead of  $d = v \cdot t$ )

Value

4% 51. (c) Two objects of masses 12.0 kg and 7.0 kg are connected by a massless string that passes over a frictionless pulley as shown.

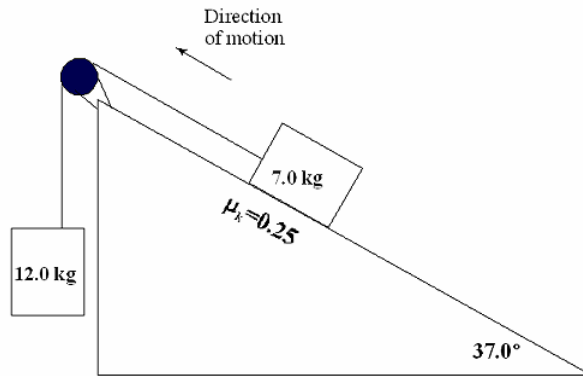

(i) Calculate the magnitude of the acceleration of the blocks.

**Answer:**

$$F_{A1} = m_1 g = (12.0)(9.80) = 118N \quad \mathbf{0.5 \text{ marks}}$$

$$F_{A2} = mg \sin \theta = (7.0)(9.80) \sin(37^\circ) = 41N \quad \mathbf{0.5 \text{ marks}}$$

$$F_{fr} = \mu mg \cos \theta = (0.25)(7.0)(9.80) \cos(37^\circ) = 14N \quad \mathbf{0.5 \text{ marks}}$$

$$\vec{a} = \frac{\vec{F}_{net}}{m} = \frac{F_{A1} + F_{A2} + F_{fr}}{m_1 + m_2} \quad \mathbf{0.5 \text{ marks}}$$

$$\vec{a} = \frac{-118 + 41 + 14}{12.0 + 7.0} \quad \mathbf{0.5 \text{ marks}}$$

$$\vec{a} = 3.3 \frac{m}{s^2} \quad \mathbf{0.5 \text{ marks}}$$

### Commentary on Response

Although the direction of motion was given, students perceived the friction force as acting to the left, in the same direction as the motion. Friction always acts against the direction of motion, in this case down the incline.

## Common Errors

Students:

- used the wrong direction (sign) for friction
- did not use the angle of the incline
- omitted the parallel component of gravity ( $m \cdot g \cdot \sin \theta$ )
- referred to the direction of the masses as being clockwise (7.0 kg) or counterclockwise (12.0 kg). This is incorrect since there is no torque, only linear motion for each mass

(ii) Calculate the magnitude of the tension in the string.

### Answer:

Isolate one mass and solve for the tension on the supporting string. For the following use the 12.0 kg hanging mass:



$$\vec{F} = m \cdot \vec{a}$$

$$T + F_{g1} = m_1 \cdot a_1$$

$$T = m_1 \cdot a_1 - F_{g1}$$

$$T = (12.0)(-3.3) - (-118)$$

$$T = 78N$$

**0.5 marks**

**0.5 marks**

## Common Errors

Students:

- added the components rather than subtracting
- omitted either  $F_g$  or  $F_{net}$  in their calculations

Value

3% 51.(d) A 1500 kg car travels at 25 m/s around a circular curve on a flat road. If the coefficient of static friction is 0.750, calculate the minimum radius of curvature the car can make.

**Answer:**

$$F_c = F_{fr} \quad \mathbf{0.5 \text{ marks}}$$

$$\frac{m \cdot v^2}{r} = \mu_s \cdot m \cdot g \quad \mathbf{0.5 \text{ marks}}$$

$$r = \frac{v^2}{\mu_s \cdot g} = \frac{(25)^2}{(0.75)(9.80)} \quad \mathbf{0.5 \text{ marks}}$$

$$r = 85m \quad \mathbf{0.5 \text{ marks}}$$

**Science communication skills** **1 mark**

### Commentary on Response

Many students had an incorrect number of significant digits.

### Common Errors

Students:

- omitted the coefficient of friction,  $\mu_s$
- did not square the speed in the centripetal force equation, even though it was stated in the formula
- made calculation errors throughout the question. Formulae were stated, values inserted properly, but answers were calculated incorrectly

Value

3% 51.(e) A 56.0 kg person suspended by cables hangs motionless as shown. Calculate the magnitude of the tension  $T_1$ ,  $T_2$  and  $T_3$  in each cable.

**Answer:**

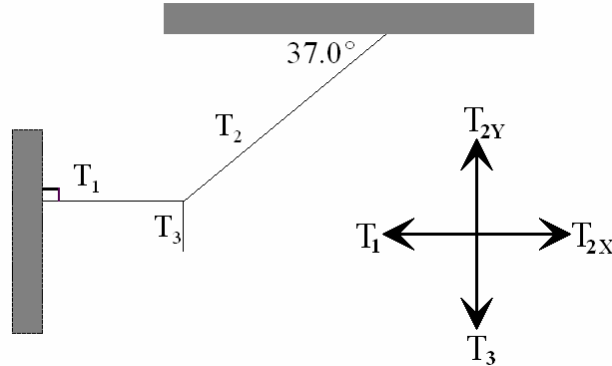

$$T_{2y} = T_3 = m \cdot g \quad \mathbf{0.5 \text{ marks}}$$

$$T_{2y} = (56.0)(9.80) \quad \mathbf{0.5 \text{ marks}}$$

$$T_{2y} = 549N$$

$$T_{2y} = T_2 \sin \theta \quad \mathbf{0.5 \text{ marks}}$$

$$549 = T_2 \sin 37 \quad \mathbf{0.5 \text{ marks}}$$

$$T_2 = 912N$$

$$T_1 = T_{2x} \quad \mathbf{0.5 \text{ marks}}$$

$$T_1 = T_2 \cos \theta$$

$$T_1 = (912) \cos(37.0^\circ) \quad \mathbf{0.5 \text{ marks}}$$

$$T_1 = 728N$$

**Alternate method:** Many students chose to answer this question using trigonometry.

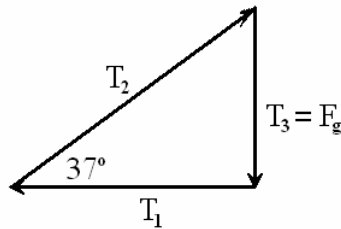

$$T_3 = F_g = (56.0)(9.80)$$

$$T_3 = 549N$$

**1 mark**

$$\frac{T_3}{T_1} = \tan\theta$$

$$T_1 = \frac{T_3}{\tan\theta} = \frac{549}{\tan(37)} = 729N$$

**1 mark**

$$T_2^2 = T_1^2 + T_3^2$$

$$T_2^2 = 729^2 + 549^2$$

$$T_2 = 913N$$

**1 mark**

### Common Errors

Students:

- used sine instead of cosine & vice versa
- used angles inappropriately in equations (e.g., when there were no components to consider)
- added  $T_3$  to  $F_g$ , rather than equating them
- divided the final answer by two
- applied torque to the question

Value

4% 51. (f) A 20.0 kg sign is supported at the end of a 2.50 m horizontal beam of mass 21.0 kg that is hinged to a pole as shown.

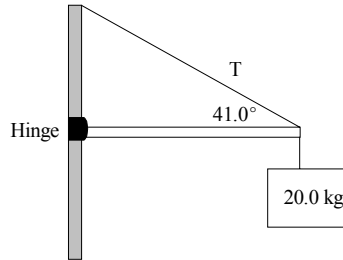

i) Calculate the magnitude of the tension in the cable.

**Answer:**

$$\tau_{Beam} = F_B \times r_B = (21.0)(9.80)(2.50 / 2) = 258 N \cdot m$$

**0.5 marks**

$$\tau_{Sign} = F_S \times r_S = (20.0)(9.80)(2.50) = 490 N \cdot m$$

**0.5 marks**

$$\tau_{cable} = F_C \sin(\theta) \times r_C = T \sin(41.0) \times 2.50 = T(1.64)$$

**0.5 marks**

$$\tau_{cw} = \tau_{ccw}$$

**0.5 marks**

$$\tau_{Beam} + \tau_{Sign} = \tau_{cable}$$

$$258 + 490 = T(1.64)$$

**0.5 marks**

$$748 = T(1.64)$$

**0.5 marks**

$$T = 456 N$$

### Commentary on Response

Many students failed to recognize this as a torque question.

### Common Errors

Students:

- used the wrong angle (e.g.,  $40^\circ$  instead of  $41^\circ$ )
- did not use either the y-component of the tension ( $F \cdot \sin \theta$ ), or the distance of the cable from the hinge, in calculating the torque for the cable
- did not use the force,  $F_B$  (centre of mass), or used the wrong distance from the hinge to the centre of the mass, in calculating the torque for the center of mass of the beam
- failed to include the torque due to the beam or the sign

- (ii) Calculate the magnitude of the horizontal component of the force exerted on the beam by the hinge.

**Answer:**

$$F_H = T\cos\theta$$

**0.5 marks**

$$F_H = 456\cos(41^\circ)$$

$$F_H = 344N$$

**0.5 marks**

**Commentary on Response**

Students often did not relate this part of the question to the previous part.

**Common Error**

Students used sine instead of cosine.

Value

3% 52. (a) Three charged spheres are arranged as shown. Calculate the magnitude of the net force on Y due to the presence of X and Z.

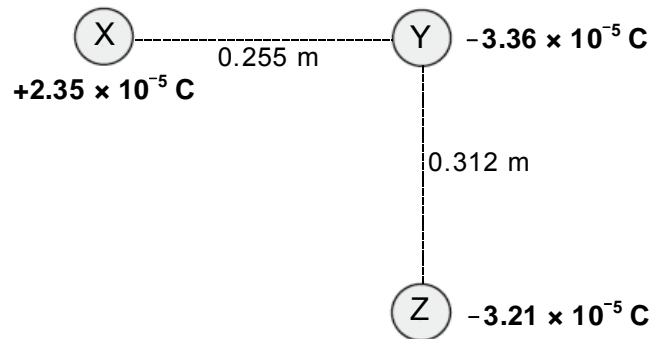

**Answer:**

$$F_{xy} = \frac{kQ_x Q_y}{r_{xy}^2} = \frac{(9.0 \times 10^9)(2.35 \times 10^{-5})(-3.36 \times 10^{-5})}{(0.255)^2} = -109.3 \text{ N} \quad \mathbf{1 \text{ mark}}$$

$$F_{zy} = \frac{kQ_z Q_y}{r_{zy}^2} = \frac{(9.0 \times 10^9)(-3.21 \times 10^{-5})(-3.36 \times 10^{-5})}{(0.312)^2} = 99.7 \text{ N} \quad \mathbf{1 \text{ mark}}$$

$$F^2 = F_{xy}^2 + F_{zy}^2$$

$$F^2 = (109.3)^2 + (99.7)^2 \quad \mathbf{1 \text{ mark}}$$

$$F = 148 \text{ N}$$

### Commentary on Response

Those students who did not score full marks often did not have an understanding of the vector nature of this problem. They also failed to differentiate this problem from an electric field problem.

### Common Errors

Students:

- used the wrong combination of charges when calculating each force component
- did not square the appropriate values when using the Pythagorean theorem to calculate net force
- used the electric field formula
- failed to treat the forces as two vector components



Value

5% 52.(c) Given the circuit in the diagram below, calculate:

- (i) the current through the  $5.00 \Omega$  resistor.

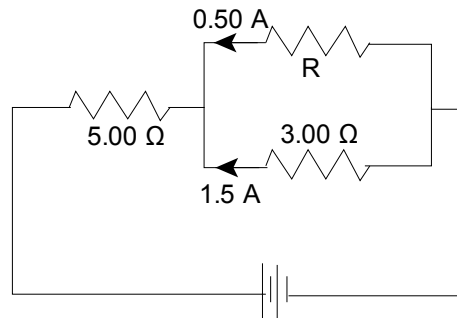

**Answer:**

$$I_5 = I_T = I_R + I_3$$

$$I_5 = 0.50A + 1.5A$$

$$I_5 = 2.0A$$

**1 mark**

**Common Error**

Students did not use Kirchoff's current rule.

- (ii) the resistance of R.

**Answer:**

$$V_R = V_3 = I_3 \cdot R_3 = (1.5)(3.00)$$

$$V_R = 4.5V$$

$$R = \frac{V_R}{I_R} = \frac{4.5}{0.50}$$

$$R = 9.0\Omega$$

**1 mark**

**1 mark**

**Common Error**

Students who solved the parallel resistance using ratios did so incorrectly. They assumed the current was directly proportional to the resistance

(iii) the potential difference across the battery.

**Answer:**

$$V_s = I_s \cdot R_s = (5.00)(2.0)$$

**1 mark**

$$V_s = 10\text{V}$$

$$V_T = V_s + V_p = 10 + 4.5$$

**1 mark**

$$V_T = 14.5\text{V}$$

**Common Error**

Many students used the sum of all voltages as the total voltage.

Value

3% 52. (d) A soldering iron of resistance  $576 \Omega$  is connected to a 120 V circuit. Calculate the cost to operate the soldering iron 8.0 hours a day for 21 days, if energy costs  $\$0.080/\text{kW}\cdot\text{h}$ .

**Answer:**

$$P = \frac{V^2}{R} = \frac{(120)^2}{576} = 25W \quad \mathbf{0.5 \text{ marks}}$$

$$P = 0.025kW \quad \mathbf{0.5 \text{ marks}}$$

$$E = P \cdot t = (0.025)\left(8 \frac{\text{hr}}{\text{d}}\right)(21d) \quad \mathbf{0.5 \text{ marks}}$$

$$E = 4.2kWh$$

$$\text{cost} = E \cdot t = (4.2)(0.08) \quad \mathbf{0.5 \text{ marks}}$$

$$\text{cost} = \$0.34$$

**Science Communication skills** **1 mark**

### Common Errors

Students:

- did not convert from Watts to kilowatts
- calculated the cost incorrectly. They divided energy by price/kWh rather than multiplying energy by price/kWh.

Value

- 3% 52. (e) The magnetic field surrounding the current-carrying wire shown below has magnitude  $2.9 \times 10^{-5} \text{ T}$ , and is directed into the page at point P. Calculate the magnitude and direction of the current in the wire.

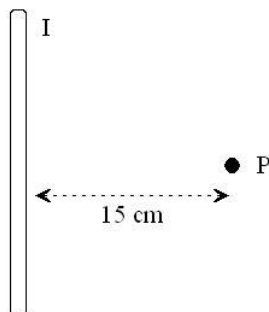

**Answer:**

$$r = 15 \text{ cm} = 0.15 \text{ m} \quad \mathbf{0.5 \text{ marks}}$$

$$B = \frac{\mu_0 I}{2\pi r} \quad \mathbf{0.5 \text{ marks}}$$

$$I = \frac{2\pi Br}{\mu_0} = \frac{2\pi Br}{4\pi \times 10^{-7}} = \frac{(2.9 \times 10^{-5})(0.15)}{2 \times 10^{-7}} \quad \mathbf{0.5 \text{ marks}}$$

$$I = 22 \text{ A} \quad \mathbf{0.5 \text{ marks}}$$

Current is downward  $\mathbf{1 \text{ mark}}$

### Commentary on Response

Students appeared confused over point “P”. The question stated that the magnetic field moved into the page, but the actual point at “P,” although large, was sometimes interpreted as the field moving out of the page.

### Common Errors

Students:

- used the wrong formula (e.g.,  $F = BIl \cdot \sin \theta$  instead of  $F = \frac{\mu_0 I}{2\pi r}$ )
- used incorrect direction for current flow
- confused direction of magnetic fields with current direction
- did not convert from cm to m

Value

3% 52. (f) An electron travelling at  $7.7 \times 10^6$  m/s enters a uniform magnetic field at a right angle. When inside the field, the curved path of the electron has a radius of  $3.5 \times 10^{-2}$  m. Calculate the magnitude of the magnetic field.

**Answer:**

$$F_B = F_c$$

$$qvB = \frac{mv^2}{r}$$

**1 mark**

$$B = \frac{mv}{rq}$$

**0.5 marks**

$$B = \frac{(9.11 \times 10^{-31})(7.7 \times 10^6)}{(3.5 \times 10^{-2})(1.6 \times 10^{-19})}$$

**1 mark**

$$B = 1.3 \times 10^{-3} T$$

**0.5 marks**

### Common Error

Students:

- did not square the speed in the centripetal force equation
- used the incorrect formula (e.g., using  $F = \frac{\mu I}{2\pi r}$  instead of  $F = qvB \cdot \sin\theta$ )
- equated centripetal force with electric force instead of centripetal force with magnetic force

Value

2% 53.(a) Calculate the energy (in Joules) gained by an electron in a hydrogen atom as it moves from the second to the fifth energy level.

**Answer:**

$$E_2 = \frac{-13.6}{2^2} = -3.40\text{eV} \quad \mathbf{0.5 \text{ marks}}$$

$$E_5 = \frac{-13.6}{5^2} = -0.544\text{eV} \quad \mathbf{0.5 \text{ marks}}$$

$$\Delta E = E_{upper} - E_{lower} \quad \mathbf{0.5 \text{ marks}}$$
$$\Delta E = -0.544 - (-3.40)$$

$$\Delta E = 2.856\text{eV} \quad \mathbf{0.5 \text{ marks}}$$
$$\text{or } 4.6 \times 10^{-19} \text{ J}$$

### Commentary on Response

Students did not seem to know that changing energy states involved finding the difference in energies at each level.

### Common Errors

Students:

- used the radii formula, instead of the energy level formula, but still subtracted values to find a difference, thinking it was an energy difference
- subtracted energy levels ( $5 - 2 = 3$ ) and used this difference in calculating the energy

Value

- 3% 53.(b) In a photoelectric effect experiment, light is shone on a metal surface. The graph below illustrates the maximum kinetic energy of ejected electrons versus frequency of the incident light of the photons.

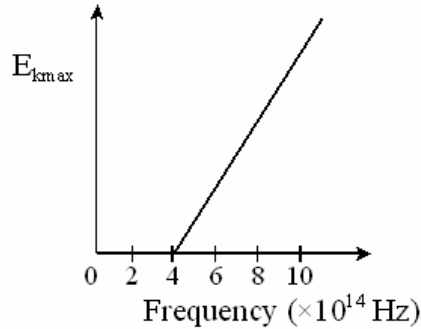

- (i) Use the graph to determine a frequency at which the photoelectric effect will **not** occur, and explain why it will not occur.

**Answer:**

Any frequency in the range:  $0 < f < 4 \times 10^{14}$  Hz

**0.5 marks**

Electrons will not be emitted from the metal for any frequency with values in this range because the threshold frequency ( $4 \times 10^{14}$  Hz) is not exceeded.

**0.5 marks**

**Common Error**

Students interpreted  $E_{kmax}$  as the energy of the photon, and not as the kinetic energy of the electron.

(ii) Determine the work function of the metal.

**Answer:**

$$W = h \cdot f$$

**1 mark**

$$W = (6.626 \times 10^{-34})(4 \times 10^{14})$$

**1 mark**

$$W = 2.65 \times 10^{-19} J$$

### **Commentary on Response**

Many students did not understand the concept of work function.

### **Common Errors**

Students:

- used the frequency from part (i), rather than using the threshold to calculate the work function
- did not let  $E_K = 0$  when using the relationship  $hf = E_K + W_o$ . Instead they found the kinetic energy for an electron traveling at the speed of light

Value

3% 53. (c) Calculate the half-life of a radioactive substance that decays from an initial amount of  $2.00 \times 10^{-3}$  g to  $1.35 \times 10^{-4}$  g in 3.0 h.

**Answer:**

$$N = N_o \left( \frac{1}{2} \right)^{\frac{t}{T_{\frac{1}{2}}}}$$

**0.5 marks**

$$\frac{N}{N_o} = \left( \frac{1}{2} \right)^{\frac{t}{T_{\frac{1}{2}}}}$$

$$\frac{1.35 \times 10^{-4}}{2.00 \times 10^{-3}} = \left( \frac{1}{2} \right)^{\frac{3.0}{T_{\frac{1}{2}}}}$$

**0.5 marks**

$$0.0675 = (0.5)^{\frac{3.0}{T_{\frac{1}{2}}}}$$

$$\log(0.0675) = \frac{3.0}{T_{\frac{1}{2}}} \log(0.5)$$

**0.5 marks**

$$-1.17 = \left( \frac{3.0}{T_{\frac{1}{2}}} \right) - 0.301$$

$$T_{\frac{1}{2}} = 0.77h$$

**0.5 marks**

**Science communication skills**

**1 mark**

### Common Errors

Students:

- found time instead of half-life. They appeared to confuse time with half-life (e.g.,  $\frac{t}{3}$ , instead of  $\frac{3}{t}$ )
- used the wrong order of operations, commonly multiplying the base by the coefficient (e.g.,  $(2.0 \times 10^{-3}) \left( \frac{1}{2} \right)^x = (1.0 \times 10^{-3})^x$ )
- used the subscript  $\frac{1}{2}$ , as a coefficient (e.g.,  $t_{\frac{1}{2}} \rightarrow t \left( \frac{1}{2} \right)$ )

Value

2% 53.(d) Calculate the energy produced in the reaction below.

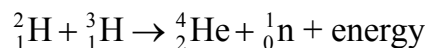

Particle	Mass (kg)
${}^2_1\text{H}$	$3.3444 \times 10^{-27}$
${}^3_1\text{H}$	$5.0082 \times 10^{-27}$
${}^4_2\text{He}$	$6.6463 \times 10^{-27}$
${}^1_0\text{n}$	$1.6749 \times 10^{-27}$

**Answer:**

$$m_{\text{before}} = 3.3444 \times 10^{-27} + 5.0082 \times 10^{-27} = 8.3526 \times 10^{-27} \text{ kg}$$

**0.5 marks**

$$m_{\text{after}} = 6.6463 \times 10^{-27} + 1.6749 \times 10^{-27} = 8.3212 \times 10^{-27} \text{ kg}$$

**0.5 marks**

$$\Delta m = m_{\text{before}} - m_{\text{after}}$$

**0.5 marks**

$$\Delta m = 8.3526 \times 10^{-27} - 8.3212 \times 10^{-27} = 3.14 \times 10^{-29} \text{ kg}$$

$$E = mc^2 = (3.14 \times 10^{-29})(3.00 \times 10^8)^2$$

**0.5 marks**

$$E = 2.83 \times 10^{-12} \text{ J}$$

### Common Errors

Students:

- calculated mass incorrectly i.e.  ${}^3_1\text{H} = 3 \times \text{mass}$
- did not square the speed of light

**TABLE 1**  
**PHYSICS 3204 ITEM ANALYSIS**  
**SELECTED RESPONSE (PART I)**

Item	Answer	Responses			
		A	B	C	D
		%	%	%	%
1	A	68.0	8.4	2.5	21.0
2	B	29.1	61.9	5.9	3.0
3	B	9.5	71.8	13.1	5.6
4	B	14.1	64.1	4.7	17.1
5	A	27.9	56.7	8.3	7.0
6	B	2.0	64.5	20.6	12.9
7	B	7.9	69.0	8.7	14.4
8	C	15.7	4.5	75.5	4.2
9	C	17.0	11.3	57.6	14.0
10	D	26.5	36.8	5.8	30.9
11	A	55.4	21.3	16.1	6.9
12	D	0.7	6.3	6.8	86.1
13	D	4.2	21.4	2.2	72.2
14	C	5.6	2.4	71.1	20.8
15	A	75.9	8.2	8.2	6.7
16	A	90.0	4.3	2.6	3.0
17	D	0.9	5.5	1.6	91.9
18	C	19.7	6.1	68.2	5.9
19	A	69.1	11.4	0.7	18.8
20	C	25.9	25.5	38.4	10.0
21	A	65.5	14.7	15.1	4.7
22	C	4.0	41.0	39.6	15.4
23	B	4.2	77.8	8.9	9.0
24	D	2.8	12.3	6.8	78.0
25	B	11.7	41.7	34.5	11.4

Item	Answer	Responses			
		A	B	C	D
		%	%	%	%
26	D	4.2	7.2	8.5	80.2
27	D	3.5	8.6	10.3	77.6
28	C	16.6	22.3	47.0	13.9
29	B	5.7	86.5	2.6	5.1
30	A	52.9	31.7	10.6	4.7
31	C	13.9	4.1	73.9	8.1
32	C	5.5	10.0	67.1	17.2
33	A	68.2	6.5	14.7	10.3
34	D	6.3	2.2	10.4	81.0
35	D	29.4	18.3	16.4	35.9
36	C	4.8	17.0	74.4	3.7
37	B	10.8	70.8	6.1	12.2
38	C	32.0	15.0	37.9	15.1
39	D	5.9	5.6	4.6	83.5
40	C	13.9	23.3	54.6	8.1
41	A	44.9	12.0	6.8	36.1
42	A	78.8	13.2	5.9	1.9
43	B	7.7	53.7	29.6	8.3
44	A	58.6	20.5	12.0	8.5
45	B	8.0	70.1	15.6	6.3
46	A	68.0	13.2	16.1	2.6
47	A	68.7	8.6	19.6	2.9
48	B	18.2	76.8	2.6	2.3
49	A	86.0	3.4	7.4	3.1
50	A	88.5	4.7	2.5	4.2

NOTE: Percentages may not add to 100% due to multiple responses or missing values.

**TABLE 2**  
**PHYSICS 3204 ITEM ANALYSIS**  
**CONSTRUCTEDRESPONSE (PART II)**

<b>Item</b>	<b>Students Completing Item</b>	<b>Value</b>	<b>Average</b>
51. (a)	1155	3	2.3
51. (b)	1155	3	2.0
51. (c)	1155	4	2.9
51. (d)	1155	3	2.3
51. (e)	1155	3	1.6
51. (f)	1155	4	2.3
52. (a)	1155	3	2.4
52. (b)	1155	3	1.1
52. (c)	1155	5	3.4
52. (d)	1155	3	2.1
52. (e)	1155	3	1.6
52. (f)	1155	3	1.6
53. (a)	1155	2	1.4
53. (b)	1155	3	1.8
53. (c)	1155	3	2.3
53. (d)	1155	2	1.4